



# LINE SHAFTS

## 5 - 25,000 Nm



### GENERAL INFORMATION R+W LINE SHAFTS:



#### SERVICE LIFE

R+W line shafts are wear and maintenance free for an infinite service life, as long as the technical limits are not exceeded.

#### FIT CLEARANCE

Overall shaft / hub clearance of 0.01 - 0.05 mm

#### ROTATIONAL SPEED

After selecting overall length A, contact R+W for maximum speed.

#### SPECIAL SOLUTIONS

Various materials, tolerances, dimensions and performance ratings available for custom applications on request.

#### ATEX (Optional)





For use in hazardous zones 1/21 and 2/22, R+W line shafts have been authorized under directive 94/9/EG and is available with certification.



## BACKLASH FREE, TORSIONALLY STIFF LINE SHAFTS 10 - 4,000 Nm

MODEL

FEATURES

<b>ZA</b>		<b>with clamping hub from 10 - 800 Nm</b> <ul style="list-style-type: none"><li>▶ installation and removal possible without disturbing other machine components</li><li>▶ standard lengths up to 6 meters</li><li>▶ no intermediate support bearings required</li></ul>	Page 124
<b>ZA</b>		<b>with conical clamping system from 1,500 - 4,000 Nm</b> <ul style="list-style-type: none"><li>▶ installation and removal possible without disturbing other machine components</li><li>▶ standard lengths up to 6 meters</li><li>▶ no intermediate support bearings required</li></ul>	Page 125
<b>ZAE</b>		<b>with split clamping hub from 10 - 800 Nm</b> <ul style="list-style-type: none"><li>▶ complete coupling system mounts laterally for very easy installation and removal</li><li>▶ standard lengths up to 6 meters</li><li>▶ no intermediate support bearings required</li></ul>	Page 126
<b>ZAL</b>		<b>with split clamping hub from 10 - 800 Nm</b> <ul style="list-style-type: none"><li>▶ complete coupling system mounts laterally for very easy installation and removal</li><li>▶ standard lengths up to 6 meters, with CFK tube</li><li>▶ no intermediate support bearings required</li></ul>	Page 127

## BACKLASH FREE LINE SHAFTS

### 5 - 25,000 Nm

#### MODEL

#### FEATURES

**EZ2**

**with split clamping hub  
from 9 - 25,000 Nm**

Pages 128-129

- ▶ standard lengths up to 4 meters
- ▶ no intermediate support bearings required
- ▶ complete coupling system mounts laterally for very easy installation and removal

**EZV**

**with split clamping hub,  
adjustable length  
from 12.5 - 1,200 Nm**

Pages 130-131

- ▶ adjustable length ranges up to 4 meters
- ▶ no intermediate support bearings required
- ▶ complete coupling system mounts laterally for very easy installation and removal

# ZA

## WITH CLAMPING HUB

10 - 800 Nm



### PROPERTIES

#### FEATURES

- ▶ for spanning larger distances between shaft ends
- ▶ standard lengths up to 6 meters
- ▶ no intermediate support bearings required
- ▶ extremely straight and laterally stiff intermediate tube

- ▶ **Intermediate tube:** up to size 150 aluminum, size 300 and up steel, optional CFK
- ▶ **Hubs:** up to size 60 aluminum, size 150 and up steel

#### MATERIAL

- ▶ **Bellows:** high grade stainless steel

#### DESIGN

Two clamping hubs with a single clamping screw in each. A special support system carries the weight of the tube on the hubs. Operable temperature range from -30 to +100 °C.

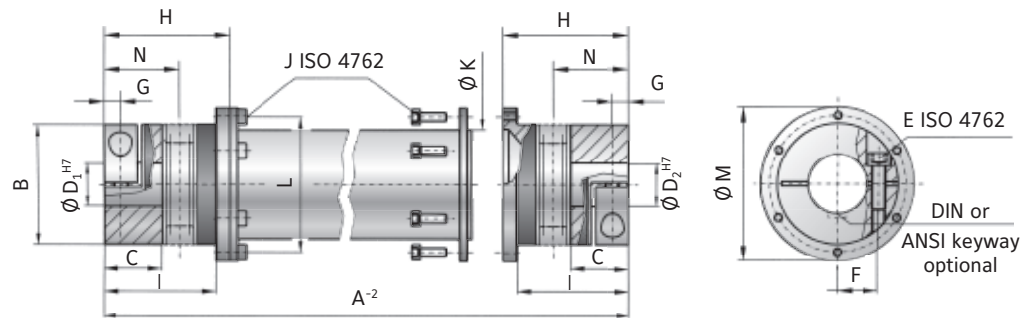

### MODEL ZA

SIZE			10	30	60	150	200	300	500	800
Rated torque (Nm)	T <sub>KN</sub>		10	30	60	150	200	300	500	800
Overall length min. to max. (mm)	A <sup>-2</sup>		110 - 6000	140 - 6000	170 - 6000	215 - 6000	215 - 6000	250 - 6000	260 - 6000	260 - 6000
Outside diameter clamping hub (mm)	B		40	55	66	81	90	110	123	134
Fit length (mm)	C		16	27	31	35.5	40.5	43	50	48
Inside diameter from Ø to Ø H7 (mm)	D <sub>1/2</sub>		5 - 20	10 - 28	12 - 32	19 - 42	22 - 45	30 - 60	35 - 60	40 - 72
With keyway max. Ø H7 (mm)	D <sub>1/2</sub>		17	23	29	36	45	60	60	66
ISO 4762 clamping screw	E		M4	M6	M8	M10	M12	M12	M16	2x M16
Tightening torque (Nm)			5	15	40	70	110	130	200	250
Distance between centers (mm)	F		15	19	23	27	31	39	41	48
Distance (mm)	G		5	7.5	9.5	11	12.5	13	17	18
Length bellows body (mm)	H		44.5	57.5	71	78	86	94	110	101
Distance (mm)	I		38.5	51	61	69	75.5	81	96	89
ISO 4762 clamping screw	J		4x M4	6x M4	6x M5	8x M6	8x M6	8x M8	8x M8	10x M8
Tightening torque (Nm)			3	4	7	10	12	30	30	40
Outside diameter tube section (mm)	K		35	50	60	76	90	100	110	120
Bolt hole circle Ø (mm)	L		45	62.5	71.5	88	100	120	132	138
Outside diameter flange (mm)	M		52	70	80	98	110	135	148	153
Shaft average value (mm)	N		25	34	41	47	52	56	66	64

For maximum misalignment values see page 16.

ORDERING EXAMPLE	ZA	10	1551	18	19.05	XX
Model	●					
Size		●				
Overall length mm			●			
Bore D1 H7				●		
Bore D2 H7					●	
Special designation only (e.g. special bore tolerance).						
For custom features place an XX at the end of the part number and describe the special requirements (e.g. ZA / 10 / 1551 / 18 / 19.05 / XX; XX=anodized aluminum)						

# ZA

## WITH CONICAL CLAMPING SYSTEM

1,500 - 4,000 Nm



### PROPERTIES

#### FEATURES

- ▶ for spanning larger distances between shaft ends
- ▶ standard lengths up to 6 meters
- ▶ no intermediate support bearings required
- ▶ extremely straight and laterally stiff intermediate tube

#### MATERIAL

- ▶ **Bellows:** high grade stainless steel

- ▶ **Intermediate tube:** steel, optional CFK
- ▶ **Hubs:** steel

#### DESIGN

Two conical clamping bushings with separate screws for mounting and dismantling. A special support system carries the weight of the tube on the hubs. Operable temperature range from -30 to +100 °C.

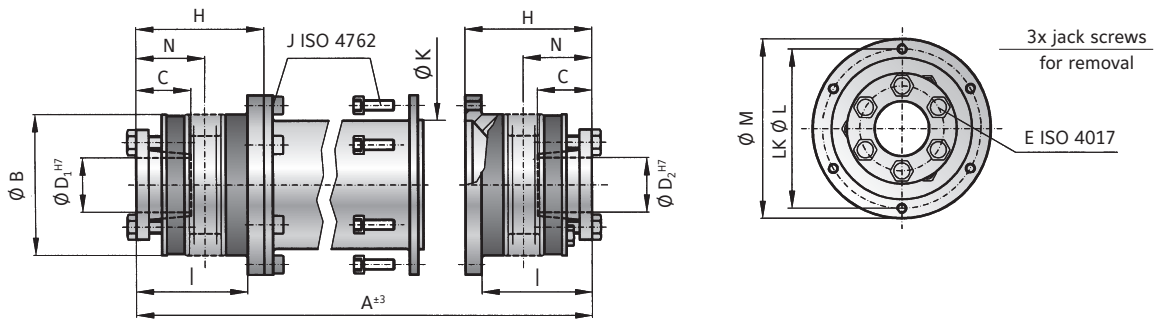

## MODEL ZA

SIZE			1500	4000
Rated torque (Nm)	$T_{KN}$		1500	4000
Overall length min. to max. (mm)	$A^{±3}$		280 - 6000	280 - 6000
Outside diameter (mm)	B		157	200
Fit length (mm)	C		61	80.5
Inside diameter from $\phi$ to $\phi H7$ (mm)	$D_{1/2}$		35 - 70	40 - 100
ISO 4017 clamping screws			6 x M12	6 x M16
Tightening torque (Nm)	E		70	120
Length bellows body (mm)	H		98	103.5
Distance (mm)	I		82	84
ISO 4762 clamping screws			10x M10	12x M12
Tightening torque (Nm)	J		70	120
Outside diameter tube section (mm)	K		150	160
Bolt hole circle $\phi$ (mm)	L		168	193
Outside diameter flange (mm)	M		184	213
Shaft average value (mm)	N		56	61

For maximum misalignment values see page 16.

ORDERING EXAMPLE	ZA	1500	2551	50.8	70	XX
Model	●					Special designation only (e.g. special bore tolerance).
Size		●				
Overall length mm			●			
Bore D1 H7				●		
Bore D2 H7					●	

For custom features place an XX at the end of the part number and describe the special requirements (e.g. ZA / 1500 / 2551 / 50.8 / 70 / XX; XX=stainless steel)

LINE SHAFTS  
ZA | EZ



# WITH SPLIT CLAMPING HUB

## 10 - 800 Nm

### PROPERTIES



#### FEATURES

- ▶ for spanning larger distances between shaft ends
- ▶ standard lengths up to 6 meters
- ▶ no intermediate support bearings required
- ▶ extremely straight and laterally stiff intermediate tube

- ▶ **Intermediate tube:** up to size 150 aluminum, size 300 and up steel
- ▶ **Hubs:** up to size 60 aluminum, size 150 and up steel

#### MATERIAL

- ▶ **Bellows:** high grade stainless steel

#### DESIGN

Two clamping hubs with two clamping screws in each. A special support system carries the weight of the tube on the hubs. Operable temperature range from -30 to +100 °C.

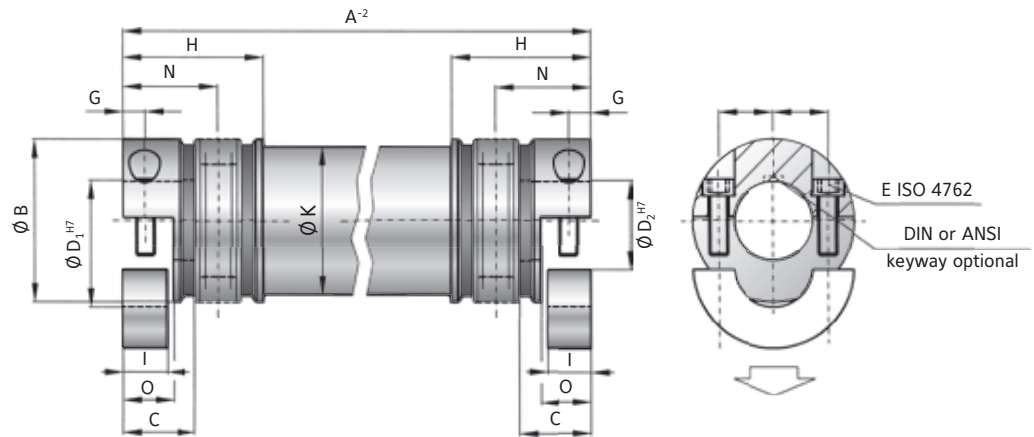

## MODEL ZAE

SIZE			10	30	60	150	300	500	800
Rated torque (Nm)	$T_{KN}$		10	30	60	150	300	500	800
Overall length min. to max. (mm)	$A^{-2}$		100 - 6000	130 - 6000	160 - 6000	180 - 6000	240 - 6000	250 - 6000	250 - 6000
Outside diameter clamping hub (mm)	B		40	55	66	81	110	123	133
Fit length (mm)	C		16	27	31	34.5	42	50	47
Inside diameter from Ø to Ø H7 (mm)	$D_{1/2}$		5 - 20	10 - 28	12 - 32	19 - 42	30 - 60	35 - 60	40 - 72
Max. inside diameter clamping hub (mm)	$D_{max}$		24	30	32	42	60	60	75
With keyway - max Ø H7 (mm)	$D_{1/2}$		17	23	29	36	60	60	66
ISO 4762 clamping screws	E		M4	M6	M8	M10	M12	M16	M16
Tightening torque (Nm)			5	15	40	70	130	200	250
Distance between centers (mm)	F		15	19	23	27	39	41	48
Distance (mm)	G		5	7.5	9.5	12	14	17	19
Length bellows body (mm)	H		39.5	52	64	72	83	96	95
Clamping length (mm)	I		10	15	19	22	28	33.5	37.5
Outside diameter tube section (mm)	K		35	50	60	76	100	110	120
Length (mm)	O		11.5	17	21	24	30	35.5	40
Shaft average value (mm)	N		25	34	41	47	56	66	65

For maximum misalignment values see page 16.

ORDERING EXAMPLE	ZAE	10	1551	18	19.05	XX
Model	●					Special designation only (e.g. special bore tolerance).
Size		●				
Overall length mm			●			
Bore D1 H7				●		
Bore D2 H7					●	
For custom features place an XX at the end of the part number and describe the special requirements (e.g. ZAE / 10 / 1551 / 18 / 19.05 / XX; XX=anodized aluminum)						



## WITH CFK INTERMEDIATE TUBE AND SPLIT CLAMPING HUB 10 - 800 Nm



### PROPERTIES

#### FEATURES

- ▶ low moment of inertia
- ▶ for spanning larger distances between shaft ends
- ▶ standard lengths up to 6 meters
- ▶ no intermediate support bearings required
- ▶ good for higher speeds

#### ▶ Intermediate tube: CFK

- ▶ Hubs: up to size 60 aluminum, size 150 and up steel

#### DESIGN

Two clamping hubs with two clamping screws in each. A special support system carries the weight of the tube on the hubs. Operable temperature range from -30 to +100 °C.

#### MATERIAL

- ▶ Bellows: high grade stainless steel

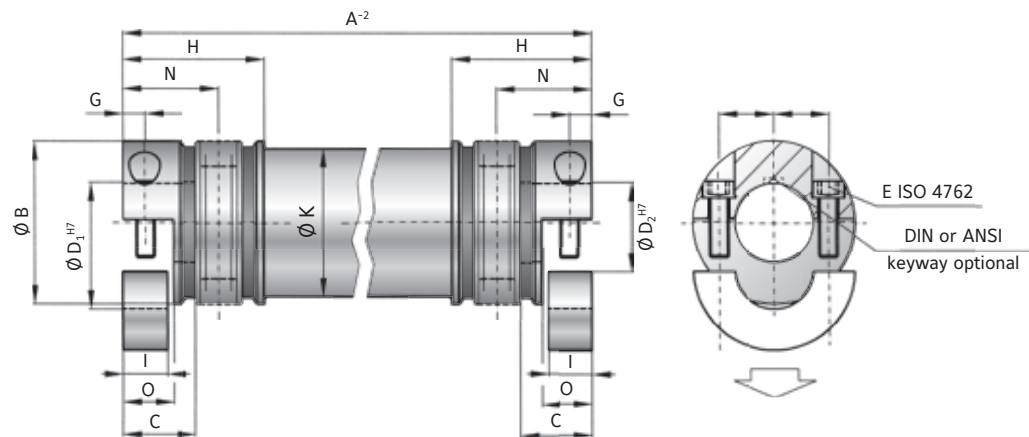

### MODEL ZAL

SIZE			10	30	60	150	300	500	800
Rated torque (Nm)	$T_{KN}$		10	30	60	150	300	500	800
Overall length min. to max. (mm)	$A^{-2}$		100 - 6000	130 - 6000	160 - 6000	180 - 6000	240 - 6000	250 - 6000	250 - 6000
Outside diameter clamping hub (mm)	B		40	55	66	81	110	123	133
Fit length (mm)	C		16	27	31	34.5	42	50	47
Inside diameter from $\emptyset$ to $\emptyset$ H7 (mm)	$D_{1/2}$		5 - 20	10 - 28	12 - 32	19 - 42	30 - 60	35 - 60	40 - 72
Max. inside diameter clamping hub (mm)	$D_{max}$		24	30	32	42	60	60	75
With keyway - max $\emptyset$ H7 (mm)	$D_{1/2}$		17	23	29	36	60	60	66
ISO 4762 clamping screws	E		M4	M6	M8	M10	M12	M16	M16
Tightening torque (Nm)			5	15	40	70	130	200	250
Distance between centers (mm)	F		15	19	23	27	39	41	48
Distance (mm)	G		5	7.5	9.5	12	14	17	19
Length bellows body (mm)	H		39.5	52	64	72	83	96	95
Clamping length (mm)	I		10	15	19	22	28	33.5	37.5
Outside diameter tube section (mm)	K		35	50	60	76	100	110	120
Length (mm)	O		11.5	17	21	24	30	35	40
Shaft average value (mm)	N		25	34	41	47	56	66	65

For maximum misalignment values see page 16.

ORDERING EXAMPLE	ZAL	10	1551	18	19.05	XX
Model	●					
Size		●				
Overall length mm			●			
Bore D1 H7				●		
Bore D2 H7					●	
For custom features place an XX at the end of the part number and describe the special requirements (e.g. ZAL / 10 / 1551 / 18 / 19.05 / XX; XX=anodized aluminum hubs)						

**EZ2**

# WITH SPLIT CLAMPING HUB

9 - 25,000 Nm



## PROPERTIES

### FEATURES

- ▶ easy installation and removal
- ▶ standard lengths up to 4 meters
- ▶ no intermediate support bearings required

### MATERIAL

- ▶ **Hubs:** up to size 450 high strength aluminum, size 800 steel, size 2500 and up GGG40
- ▶ **Intermediate tube:** up to size 450 high strength aluminum, size 800 and up steel, optional CFK tube on request

- ▶ **Elastomer insert:** wear resistant, thermally stable TPU

### DESIGN

Two split clamping hubs, with two clamping screws in each, and concave driving jaws. Backlash free, vibration damping, electrically isolating elastomer inserts press fit into the hubs. Precision intermediate tube with a high level of straightness and lateral stiffness.

## DESIGN | SIZE 10 - 800

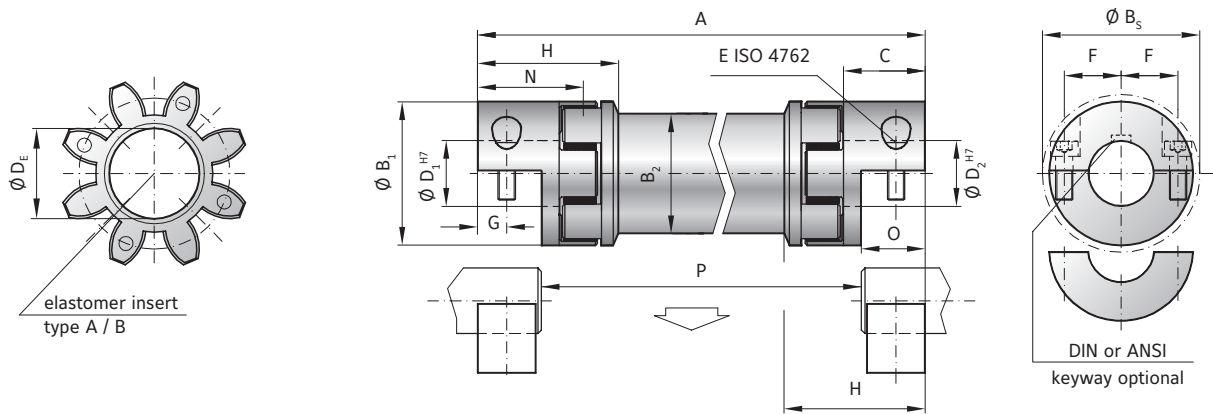

## DESIGN | SIZE 2,500 - 9,500

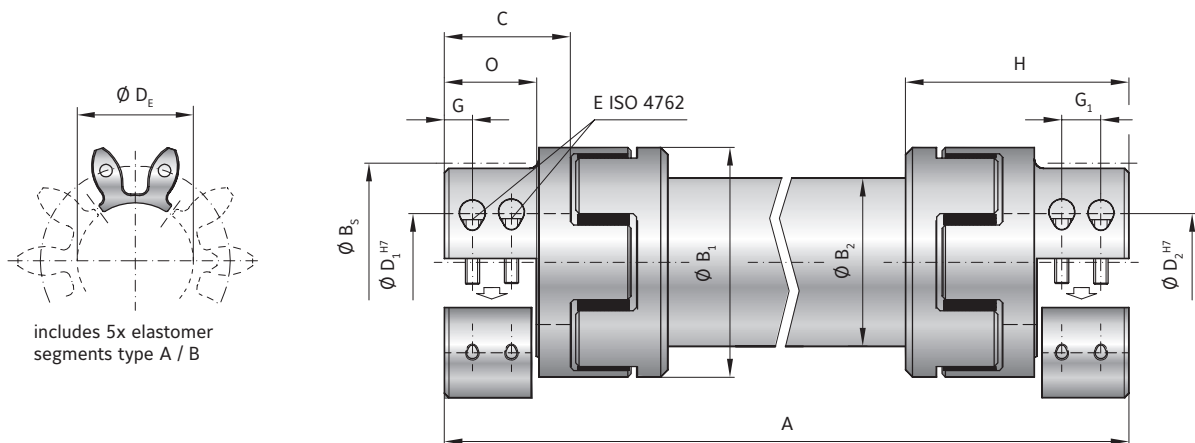

For details on the elastomer inserts see pages 72-73.



# MODEL EZ2

SIZE		5		10		20		60		150		300		450		800		2500		4500		9500	
Type (Elastomer insert)		A	B	A	B	A	B	A	B	A	B	A	B	A	B	A	B	A	B	A	B	A	B
Rated torque (Nm)	$T_{KN}$	9	12	12.5	16	17	21	60	75	160	200	325	405	530	660	950	1,100	1,950	2,450	5,000	6,200	10,000	12,500
Max. torque* (Nm)	$T_{Kmax}$	18	24	25	32	34	42	120	150	320	400	650	810	1060	1350	1,900	2,150	3,900	4,900	10,000	12,400	20,000	25,000
Overall length (mm)	A	75 - 3,000		95 - 4,000		130 - 4,000		175 - 4,000		200 - 4,000		245 - 4,000		280 - 4,000		320 - 4,000		460 - 4,000		580 - 4,000		710 - 4,000	
Outside diameter hub (mm)	$B_1$	25		32		42		56		66.5		82		102		136.5		160		225		290	
Outside diameter tube (mm)	$B_2$	25		28		35		50		60		76		90		120		150		175		220	
Outside diameter with screwhead(mm)	$B_3$	25		32		44.5		57		68		85		105		139		155		199		243	
Fit length (mm)	C	13		20		25		40		47		55		65		79		88		110		140	
Inside diameter range from $\emptyset$ to $\emptyset$ H7 (mm)	$D_{1/2}$	5 - 12.7		5 - 16		8 - 25		14 - 32		19 - 36		19 - 45		24 - 60		35 - 80		35 - 90		40 - 120		50 - 140	
Max. inside diameter (Elastomer insert) (mm)	$D_E$	10.2		14.2		19.2		26.2		29.2		36.2		46.2		60.5		80		111		145	
Mounting screw ISO 4762	E	4 x M3		4 x M4		4 x M5		4 x M6		4 x M8		4 x M10		4 x M12		4 x M16		4 x M16		8 x M20		8 x M24	
Tightening torque (Nm)		2		4		8		15		35		70		120		290		300		600		980	
Distance between centers (mm)	F	8		10.5		15.5		21		24		29		38		50.5		57		75		90	
Distance (mm)	$G/G_1$	5		7.5		8.5		15		17.5		20		25		30		18/30		24 /41		30 / 48	
Coupling length(mm)	H	25		34		46		63		73		84		97		128		142		181		229	
Moment of inertia per hub ( $10^{-3}$ kgm <sup>2</sup> )	$J_1/J_2$	0.004		0.01		0.02		0.15		0.21		1.02		2.3		17		30		140		450	
Inertia of tube per meter ( $10^{-3}$ kgm <sup>2</sup> )	$J_3$	0.049		0.075		0.183		0.66		1.18		2.48		10.6		38		360		750		1,800	
Combined dynamic torsional stiffness of the inserts (Nm/rad)	$C_{Tdyn}^E$	150	350	270	825	1,270	2,220	3,970	5,950	6,700	14,650	11,850	20,200	27,700	40,600	41,300	90,000	87,500	108,000	168,500	371,500	590,000	670,000
Torsional stiffness of tube per meter (Nm/rad)	$C_{TZR}^E$	503		321		1,530		6,632		11,810		20,230		65,340		392,800		1,000,000		2,500,000		5,000,000	
Shaft average value (mm)	N	18		26		33		49		57		67		78		94		108		137		171	
Length (mm)	O	11		16.6		18.6		32		37		42		52		62		67		85		105	

\* Maximum transmittable torque of the clamping hub depends on the bore diameter (see pages 78).

## INSTALLATION

The overall length A is best determined as the distance between shaft ends P plus 2x dimension O.

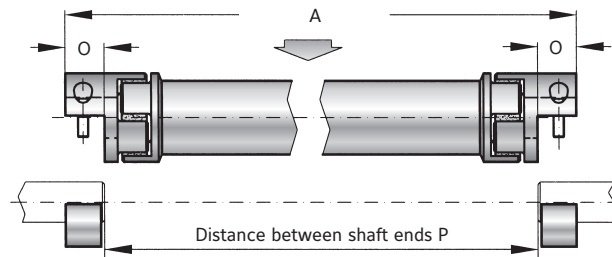

ORDERING EXAMPLE	EZ2	20	1200	A	24	19.05	XX
Model	●						Special designation only (e.g. special bore tolerance).
Size		●					
Overall length mm			●				
Elastomer insert type				●			
Bore D1 H7					●		
Bore D2 H7						●	
For custom features place an XX at the end of the part number and describe the special requirements (e.g. EZ2 / 20 / 1200 / A / 24 / 19.05 / XX; XX=anodized aluminum)							



# ADJUSTABLE LENGTH WITH SPLIT CLAMPING HUB 12.5 - 1,200 Nm

## PROPERTIES



### FEATURES

- ▶ telescoping for adjustable length and rotational orientation
- ▶ very easy to install and remove
- ▶ no intermediate support bearings required
- ▶ length ranges up to 4 meters

### MATERIAL

- ▶ **Hubs:** high strength aluminum
- ▶ **Intermediate tube:** highly straight and concentric aluminum tubing
- ▶ **Elastomer insert:** wear resistant, thermally stable TPU

### DESIGN

Two split clamping hubs, with two clamping screws in each, and concave driving jaws. Backlash free, vibration damping, electrically isolating elastomer inserts press fit into the hubs. Precision intermediate tube with a high level of straightness and lateral stiffness. Outer tube clamps over inner tube to fix the overall length.

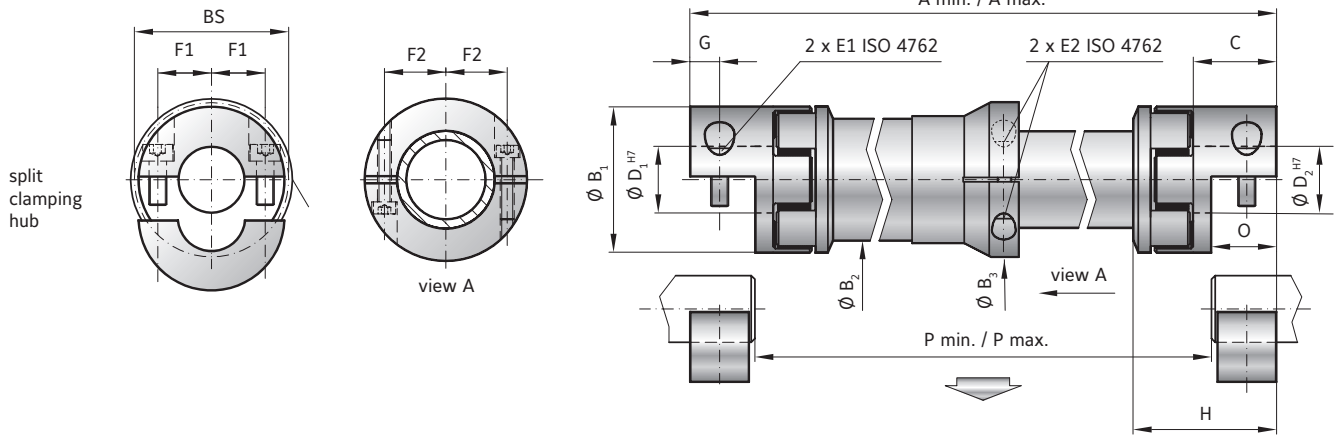

For details on the elastomer inserts see pages 72-73.

## FUNCTIONAL DESCRIPTION

The maximum extended length relates to the minimum collapsed length. The formulas to the right can be used to determine the corresponding values.

Information on sizing, torsional stiffness, misalignment ratings, etc. can be found on pages 16-18.

$$\text{Maximum extended length} = (\text{collapsed length} \times 2) - \text{measurement} (X1 + X2)$$

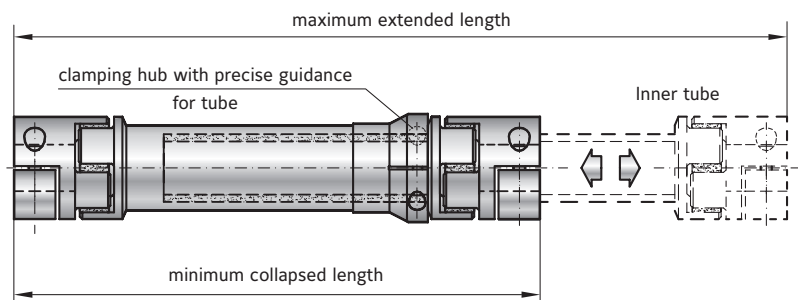

$$\text{Minimum collapsed length} = \frac{\text{maximum extended length} + \text{dimension} (X1 + X2)}{2}$$

# MODEL EZV

SIZE			10		20		60		150		300		450	
Type (Elastomer insert)			A	B	A	B	A	B	A	B	A	B	A	B
Rated torque (Nm)	$T_{KN}$		12.5	16	17	21	60	75	160	200	325	405	530	660
Max. torque* (Nm)	$T_{Kmax}$		25	32	34	42	120	150	320	400	650	810	1060	1200
Inserted min. length from - to (mm)	$A_{min}$		150 - 2,055		200 - 2,075		250 - 2,095		300 - 2,115		350 - 2,130		400 - 2,150	
Extended over all length from - to (mm)	$A_{max}$		190 - 4,000		250 - 4,000		310 - 4,000		370 - 4,000		440 - 4,000		500 - 4,000	
Measurement (mm)	X1+X2		115		156		197		240		280		312	
Outside diameter clamping hub (mm)	$B_1$		32		42		56		66.5		82		102	
Outside diameter tube (mm)	$B_2$		28		35		50		60		80		90	
Outside diameter center hub (mm)	$B_3$		41.5		47		67		77		102		115	
Outside diameter with screwhead (mm)	$B_5$		32		44.5		57		68		85		105	
Fit length (mm)	C		20		25		40		47		55		65	
Inside diameter from $\varnothing$ to $\varnothing$ H7 (mm)	$D_{1/2}$		5 - 16		8 - 25		14 - 32		19 - 35		19 - 45		24 - 60	
Screw ISO 4762	$E_1$		M4		M5		M6		M8		M10		M12	
Tightening torque (Nm)			4		8		15		35		70		120	
Screw ISO 4762	$E_2$		M4		M4		M5		M6		M8		M10	
Tightening torque (Nm)			4		4.5		8		18		35		70	
Distance between centers (mm)	$F_{10.5}$		10.5		15.5		21		24		29		38	
Distance between centers (mm)	$F_2$		15		18		26		31		41		45	
Distance (mm)	G		7.5		8.5		15		17.5		20		25	
Coupling length (mm)	H		34		46		63		73		86		99	
Shaft average value (mm)	N		26		33		49		57		67		78	
Length (mm)	O		16.6		18.6		32		37		42		52	
Moment of inertia coupling half ( $10^{-3}$ kgm <sup>2</sup> )	$J_1/J_2$		0.01		0.02		0.15		0.21		1.02		2.3	
Inertia of tube per meter ( $10^{-3}$ kgm <sup>2</sup> )	$J_3$		0.075		0.183		0.66		1.18		2.48		10.6	
Combined dynamic torsional stiffness of the inserts (Nm/rad)	$C_{1dyn}^E$		270	825	1,270	2,220	3,970	5,950	6,700	14,650	11,850	20,200	27,700	40,600
Torsional stiffness of tube per meter (Nm/rad)	$C_1^{ZWR}$		321		1,530		6,632		11,810		20,230		65,340	

\*Maximum transmittable torque of the clamping hub depends on the bore diameter (see pages 78).

ORDERING EXAMPLE	EZV	20	1200	A	24	19.05	XX
Model	●						Special designation only (e.g. special bore tolerance).
Size		●					
Collapsed length			●				
Elastomer insert type				●			
Bore D1 H7					●		
Bore D2 H7						●	
For custom features place an XX at the end of the part number and describe the special requirements (e.g. EZV / 20 / 1200 / A / 24 / 19.05 / XX; XX=anodized aluminum)							